

## Specifications

### Supply

207-265 VAC or  
104 -127 VAC (To Order)  
50/60Hz - 6VA max

### Environment

0 to 40°C operating  
-10 to +50 Storage

### Outputs

Standard - (Single Pole N.O.)

- 230V 6A max
- Control, Alarm and Trip outputs  
can switch 230VAC 30A Max when  
wired as shown.  
(See installation notes)

### Option

- SSR > 5V @ 40mA

### Connections

2 part removable connectors  
Max wire Capacity - 2.5mm<sup>2</sup>

### Thermocouple

Selectable R, S, K, N

### Range

R/S -20 to 1600 °C (2912 °F)

K/N 0 to 1300 °C (2372 °F)

Resolution 1 Degree

### Accuracy

+/- 0.1% FSD +/-1digit

### Control

Adaptive PID

### Enclosure

Dimensions

W - 120 x H - 190 x D - 75 mm

Fixing

108mm on centre line

Material ABS

Alternate inserts allow Single  
or Dual cable entry holes

### Trip

Accuracy +/- 10°C



## Installation Instructions

### ST 3300 Temperature Programmer





## Warning

**Isolate supply before opening this instrument**

No user serviceable parts inside

### Safety

**It is strongly recommended that where a kiln is to be fired unattended that an additional independent over temperature safety system is fitted. (See our optional trip unit)**

Ensure there is no risk of water entering the controller or its connecting leads.

If you have not bought the kiln & controller as a package be sure you have read and followed EVERY part of this manual

Safety	1
Mounting	2
Connections	3
Trip Board	5
Three Zone	6
Plug Wiring	7
Configuration	9
Specification	11

### Declaration



This Equipment conforms to European Standards for Electrical Interference EN50081-1 and EN50082-2 when installed as described in this manual.  
(See "Electrical Connections") Compliance dated





	Display	Parameters
Enable error 1 (Slow Start)	E1	On or OFF Def = on
Enable error 2 (Alarm)	E2	On or OFF Default = on NB When set to OFF the relay still functions, but the firing is not interrupted in the event of an error condition
Pause Time limit	PL	OFF & 1 to 99 minutes Default 15
Offset	o1	=+99 to -99(°C). Def=0
Proportional Band	P1	0 to 99 Default = 13
Integral Time	I1	0 to 99 Default = 20
Derivative	d1	0 to 99 Default = 90
3 Zone		Three Zone Only
O, P, I, D		The previous four parameters are repeated for zones 2 and 3
Control Strategy (3 Zone ONLY)	CS	ABS or d IFF Def = Diff
Hardware Definition		1 = 3 Zone + Alarm 2 = 3 Zone + Event (Default)

### Output Options

Hd code	O/P 1	O/P 2	O/P 3	O/P 4
1	Main	Alarm	Zone 2	Zone 3
2	Main	Event	Zone 2	Zone 3

## Configuration

Changing the values in the list should only be undertaken by an experienced operator or engineer.

- With the instrument switched Off
- Press and hold the  key whilst turning on the power.
- Wait until the first parameter is shown
  - Use the  key to move through the list
  - Use the   keys to change parameters
- Press the  key to save the values, exit configuration and use the controller

	Display	Parameters
<b>User Level</b>		
Alarm Type	AL	OFF or bAnd or tr IP
Alarm Temp	AL	NB The band alarm will not trigger during a Ramp if a ramp rate of Full is selected
Kiln Rating (Kw)	Kr	0 (Default) to 99.9 Kw
Trip Temp (Option Board)	OT	This value is above the highest point in the program Default = 50
Engineer Level	EL	Set to 10 to proceed
<b>Engineer Level</b>		
Thermocouple type	TC	r S K n R S K or N
Temp Units	TU	OC or OF
Ramp Units	RU	r Rate °C / Hr t Time Hr.Mn
Set point Limit	SL	0 to Max of range Default 1300 R/S, 1200 K/N
Language	LA	En English dE German

## Mounting

The controller should be mounted on a vertical surface away from heat. In particular ensure that it is not exposed to direct heat from an open kiln door or lid.

Mounting is via a removable bracket

Slide the bracket from the rear of the unit and fix vertically, using No 8 wood screws.

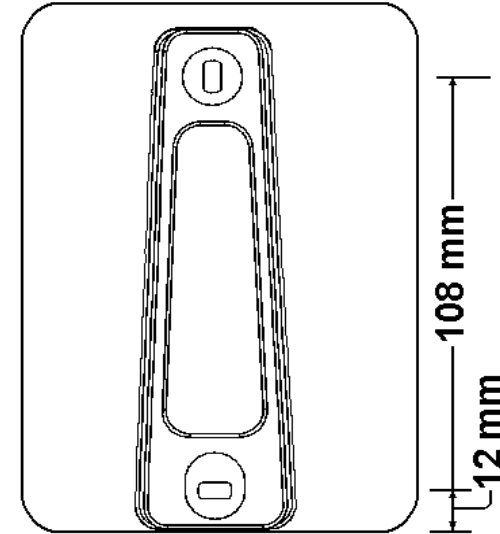

## Connections



**It is vital that all electrical installation is carried out in a professional manner.**

In most instances the controller will either have a plug, which matches your kiln, or will be connected by your supplier.

If a plug is fitted check that the pin layout of the plug and socket are an exact match before plugging in. If in doubt contact your kiln supplier.

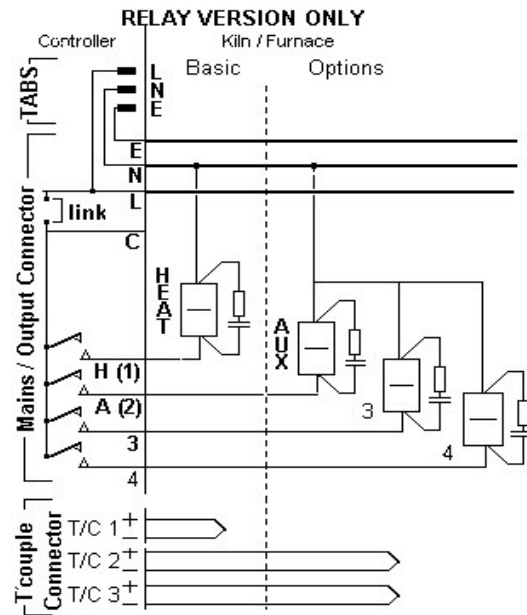
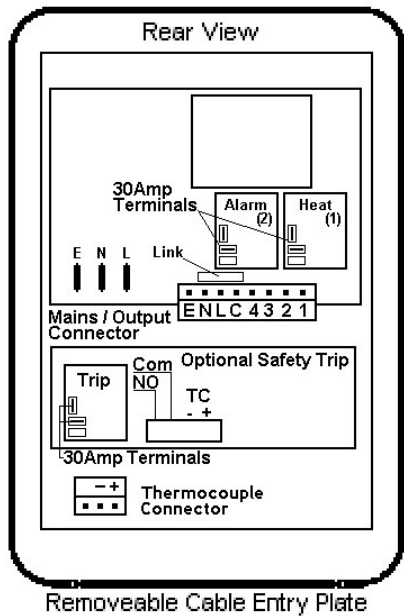

**Caution**

The terminal(s) marked 'E' adjacent to the thermocouple connections are for the connection of a screened thermocouple cable. This screen should only be connected at the instrument end. It must not connect to ground anywhere else.

The provision of a screen is essential for compliance with EMC regulations.

Use of unscreened thermocouple cables run in proximity to mains wiring constitutes a significant risk to correct operation of the unit

**Contact Suppression**

Suppressor Networks must be fitted to coil and contacts of all contactors (except safety) where shown in the accompanying diagrams.

Suitable Parts are;- Farnell218-913, RS 210-364 or 210-370

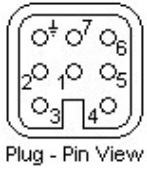

Harting Connector Wiring

- |                       |                          |
|-----------------------|--------------------------|
| 1 – Contactor Neutral | 5 – Mains Live           |
| 2 – Mains Neutral     | 6 – Heat Contactor Live  |
| 3 – Thermocouple +    | 7 – Alarm Contactor Live |
| 4 – Thermocouple -    | Earth                    |

<p><b>Electric Kiln</b> With two contactors (For single omit "Aux" wiring)</p>	<p><b>Gas Kiln</b> With High / Low fire burner and electric ignition</p>
<p><b>Damper (Event)</b> Using an external relay to drive an AC reversing motor</p>	<p><b>DC SSR Outputs</b> (To Order only) SSR outputs cannot be mixed with Relay outputs</p>
<p><b>Electric Kiln</b> Direct element switching with Control and Alarm relays. NB Not possible with event facility</p>	<p><b>115V</b> Fit links ONLY as shown Remove FS1 and fit wire link</p> <p><b>Changing Supply Voltage</b> NB The unit will work of 50 / 60 Hz supply with no change.</p>

### Optional Trip Board

Any unit may be specified to be fitted with the optional trip board. This provides an independent safety control, which uses its own thermocouple, and has a 30Amp capacity N.O. relay contact for connection to a kiln safety circuit.

The unit takes its power from the main controller; any failure of this power will cause the trip contacts to open

**Note**

- The thermocouple type must be the same as those fitted to the controller.
- The thermocouple used, or element of a duplex, must be connected to the trip only. Parallel connections with another unit will compromise the safety
- You are recommended to set the trip value as low as possible, without causing nuisance tripping. This can only be determined by experimentation on your installation

### Trip safety comparison

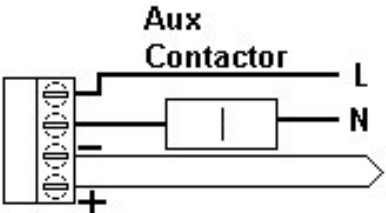
		<p><b>Electric Kiln</b> The trip board would replace the wiring to the second (Safety) contactor in the kiln.</p>
Fault Condition	Trip Option	Std Alarm
Contactor jams in	Y	Y
Control T/C shorted	Y	N
Wiring Fault	Most cases	Unlikely
Controller fault	Most cases	Unlikely

### 3 Zone or 2 Zone connections

The three zone unit is not suitable for use with 30A direct element switching. Contactors should be fitted for all control zones. The three zone unit is fitted with the trip board as standard. You are strongly advised to fit a separate safety contactor and operate this from the trip unit.

### Example wiring scheme

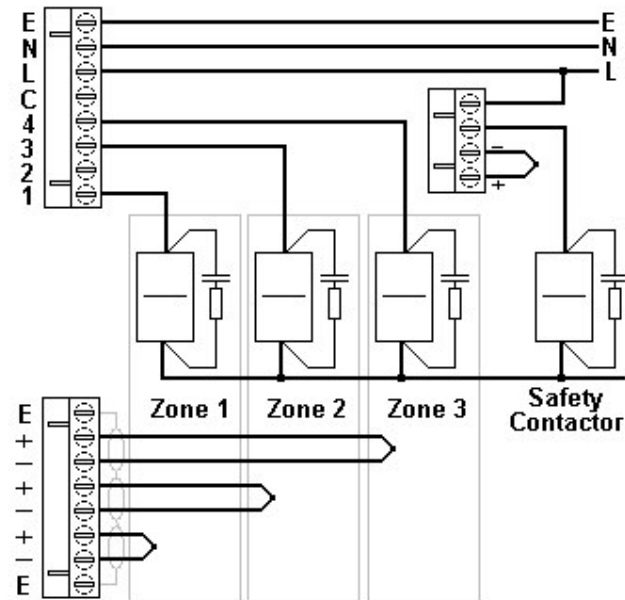

For 2 zone operation  
Omit zone 3 wiring and fit a link between + & -- for T/C 3